



CONTROL FREAK SLAMMO v3

Constant Voltage LED Dimmer

User Manual

Issue: 16 August 2010

SLAMMO v3 - Description

The SLAMMO v3 can be controlled by DALI, DSI and DMX512, but only by one of these protocols at a time. The currently active protocol can be selected using the 10-way dipswitch, which is accessible from the top of the case, or in certain circumstances be selected using the RDM (Remote Device Management) interface. Note that the SLAMMO v3 will only listen to the currently active protocol and ignore the other two (although it will always listen and respond to RDM commands). The SLAMMO v3 suits the driving of constant voltage LEDS common anode to max 150va per channel.

Selecting protocol using Dipswitches

The currently active protocol for the SLAMMO can always be selected using the 10-way dipswitch:

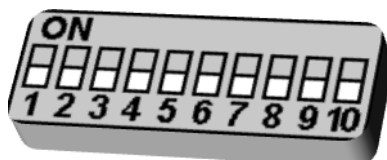

Selecting DALI with the dipswitches

To operate the SLAMMO v3 as a DALI device, turn switch 10 ON and leave all other switches OFF. The SLAMMO v3 will then immediately be able to respond to DALI levels and commands (and will use any persistent settings that have been previously programmed via DALI).

Selecting DSI with the dipswitches

To operate the SLAMMO v3 as a DSI device, turn switch 9 and 10 ON and leave all other switches OFF. The SLAMMO v3 will then immediately be able to respond to DSI levels.

Selecting DMX512 with the dipswitches

To operate the SLAMMO v3 as a DMX512 device, turn switch 10 OFF and use the other 9 switches to select the starting DMX512 address. The SLAMMO v3 will then immediately be able to respond to DMX512 levels. The valid range for the address is 1 to 511 and is selected as a binary number with switches 1 to 9:

Switch	1	2	3	4	5	6	7	8	9
Value	1	2	4	8	16	32	64	128	256

The starting DMX512 address is the sum of the values for the switches that are currently ON. Any changes to the state of the switches will immediately update the address, and the SLAMMO v3 will start responding to the new address straight away.

Selecting the active protocol with RDM

To select the active protocol using the RDM interface, turn all switches OFF. The protocol that was already programmed using RDM will then immediately be active and the SLAMMO v3 will start responding to levels and/or commands for that protocol. For details on programming the active protocol using RDM, see the RDM supplement for the SLAMMO v3. Note that the default factory setting for RDM protocol is DALI.

DALI Operation

The SLAMMO v3 complies with DALI version 1 and implements a single, standard DALI device (device type 0). To receive DALI levels and commands, the DALI terminals of the SLAMMO v3 should be connected to a DALI bus/line that also connects to a DALI power supply unit and one or more DALI controllers.

For more information on the DALI protocol, refer to the DALI Standard documentation.

DSI Operation

The SLAMMO v3 implements a single DSI device – ie 3 channels act as 1. To receive DSI levels, the DSI terminals of the SLAMMO v3 should be connected to a DSI bus/line that also connects to a DSI controller.

For more information on the DSI protocol, refer to Tridonic's DSI Protocol documentation.

DMX512 Operation

The SLAMMO v3 implements a single DMX512 device. Depending on its current personality the SLAMMO v3 will have a DMX512 footprint (i.e. how many channels it listens to) of 1, 3 or 4 channels. The personality is programmed using RDM.

DMX512 Personalities

This section outlines the three personalities that are available for DMX512 in the SLAMMO v3. More details on the functionality for each channel type is provided in the following section

Personality 1 – Basic

This personality provides the simplest DMX512 functionality for the SLAMMO v3. This is the default personality, which provides simple single channel DMX512 dimming. The following table lists the DMX512 channels that the SLAMMO v3 listens to for the basic personality:

Offset from Start Address	Channel name
+ 0	Coarse

Personality 2 – Intermediate

This personality adds on the functionality of the basic personality, providing a means of achieving smoother dimming. The following table describes the function for each DMX512 channel that the SLAMMO v3 listens to for the intermediate personality:

Offset from Start Address	Channel name
+ 0	Coarse
+ 1	Vector

Personality 3 – Advanced

This personality adds on the functionality of the intermediate personality, providing another means of achieving smoother dimming. The following table describes the function for each DMX512 channel that the SLAMMO v3 listens to for the advanced personality:

Offset from Start Address	Channel name
+ 0	Coarse
+ 1	Fine
+ 2	Vector

Personality 4 – Advanced with Strobe

This personality adds another channel to the advanced personality, providing an automatic strobe function. The following table describes the function for each DMX512 channel that the SLAMMO v3 listens to for the advanced with strobe personality:

Offset from Start Address	Channel name
+ 0	Coarse
+ 1	Fine
+ 2	Vector
+ 3	Strobe

DMX512 Channel Functions

This section outlines the functionality for each of the DMX512 channels that are available in the SLAMMO v3. Note that the number of channels that is available depends on the current personality (see previous section).

Coarse Channel

This channel sets the current output intensity. It provides a 0-255 range of levels between 0% and 100% intensity. It is effectively '8-bit', and recommended only when the DMX512 controller has limited functionality.

Fine Channel

This channel allows for greater control over the current output intensity. It provides up to a further 0-255 range of intensity levels between the current coarse output level and the next highest coarse output level. When dimming using the fine channel, the coarse and the fine levels should be treated as one value (ranging from 0-65535) and then split into two bytes when sending the DMX512 levels. Not all controllers have this functionality (sometimes called 16-bit dimming).

Vector Channel

This channel allows for a limit to be set on how fast the output intensity can change when the coarse and/or fine channels are changed. The following table outlines the functionality for different vector channel levels:

Channel level	Vector effect
0 – 5	No effect. Output will change as fast as the coarse/fine levels change.
5 – 255	Dimming rate is limited, ranging from fast (5) to slow (255). Exact rates of change are given in the next table.

The following table gives precise rates for each of the vector channel levels. Instead of specifying the rates in terms of something like output levels per second, the table shows how long it would take for the output intensity to change from 0% to 100% (or vice-versa), since this is typically a more useful way of describing the rates of change.

Channel level	Effective full-range time	Increments
0 – 5	Instant	
6 – 44	0.1s – 3.9s	0.1s
45 – 74	4s – 9.8s	0.2s
75 – 114	10s – 29.5s	0.5s
115 – 144	30s – 59s	1s
145 – 174	60s – 118s	2s
175 – 255	120s – 600s	6s

Example 1: You want to dim up over 1 second from 0 to 100% (ie the coarse channel changes from 0 to 255 and you want it to take 1 second). The vector channel would be **15** (falls in the range 0.1s – 3.9s which starts at 6, and it's 9 x 0.1s greater than 0.1s, which gives 6 + 9 = **15**).

Example 2: The coarse channel changes from a DMX512 level of 201 to a level of 100 and you want it to take 30 seconds to dim down from 201 to 101. The table above provides times based on a change of 255 (0 to 100%), and you want to work out what vector level to use based on $201 - 100 = 101$ out of 255. The closest equivalent in the table of full-range times would be $30 * (255/101) \approx 76s$, so the vector channel would be **153** (falls in the range 60s – 118s which starts at a level of 145, and it's 8 x 2s greater than 60s, which gives $145 + 8 = \mathbf{153}$).

Strobe Channel

This channel allows for the SLAMMO v3 to automatically strobe at a selectable frequency and intensity. The following table outlines the functionality for different strobe channel levels:

Channel level	Function	Idle/Strobe Intensity
0 – 7	No strobe	Always current intensity
8 – 15	One-shot strobe waiting zone	Always 0%, no strobing
16 – 23	One-shot strobe trigger zone	Idle 0%, strobe current
24 – 131	Variable frequency strobe, 0.1Hz – 10Hz	Idle 0%, strobe current
132 – 139	One-shot strobe waiting zone	Always current, no strobing
140 – 147	One-shot strobe trigger zone	Idle current, strobe 100%
148 – 255	Variable frequency strobe, 0.1Hz – 10Hz	Idle current, strobe 100%

In the table, “current intensity” refers to the output level selected by the coarse, fine and vector channels. A “one-shot” is a single strobe that occurs when the channel level moves from the “waiting zone” to the one-shot “trigger zone”. This allows for a controller to cause a strobe to occur at irregular intervals (instead of manually changing the output level), as demonstrated in the following diagram:

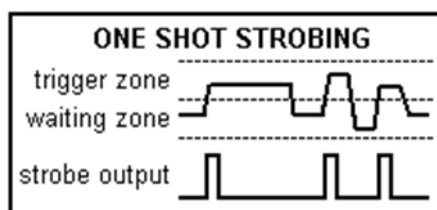

The strobe functionality for levels 8 – 131 is the same as 132 – 255, but has different idle and strobe intensities. To obtain a curve showing the exact variable strobe frequency for different strobe channel levels, please contact Creative Lighting.

RDM Interface

Details on the Remote Device Management interface implemented in the SLAMMO v3 can be found in the “SLAMMO v3 RDM Supplement” document available from Creative Lighting.

Specifications

Description	Details
Dimming Type	Pulse width modulation suits common anode bias-resisted LEDs
Physical	
Size	200mm (d) x 305mm (w) x 105mm (h)
Weight (kilograms, approximate)	0.11
Power	
DC Input	7-40VDC – match to requirement of LEDs
DC Output	7-40VDC dependant upon input voltage
Protection	Immune from accidental dc input reversal to pcb
Data Protocol	DALI, DMX512, DSI
Site considerations – important!	SLAMMO v3’s without inbuilt fans rely on convection cooling – ensure that adequate air movement and or cooling is provided to maintain internal SLAMMO v3 temperature at or below 55 degrees C

SLAMMO V3 Connection Diagram

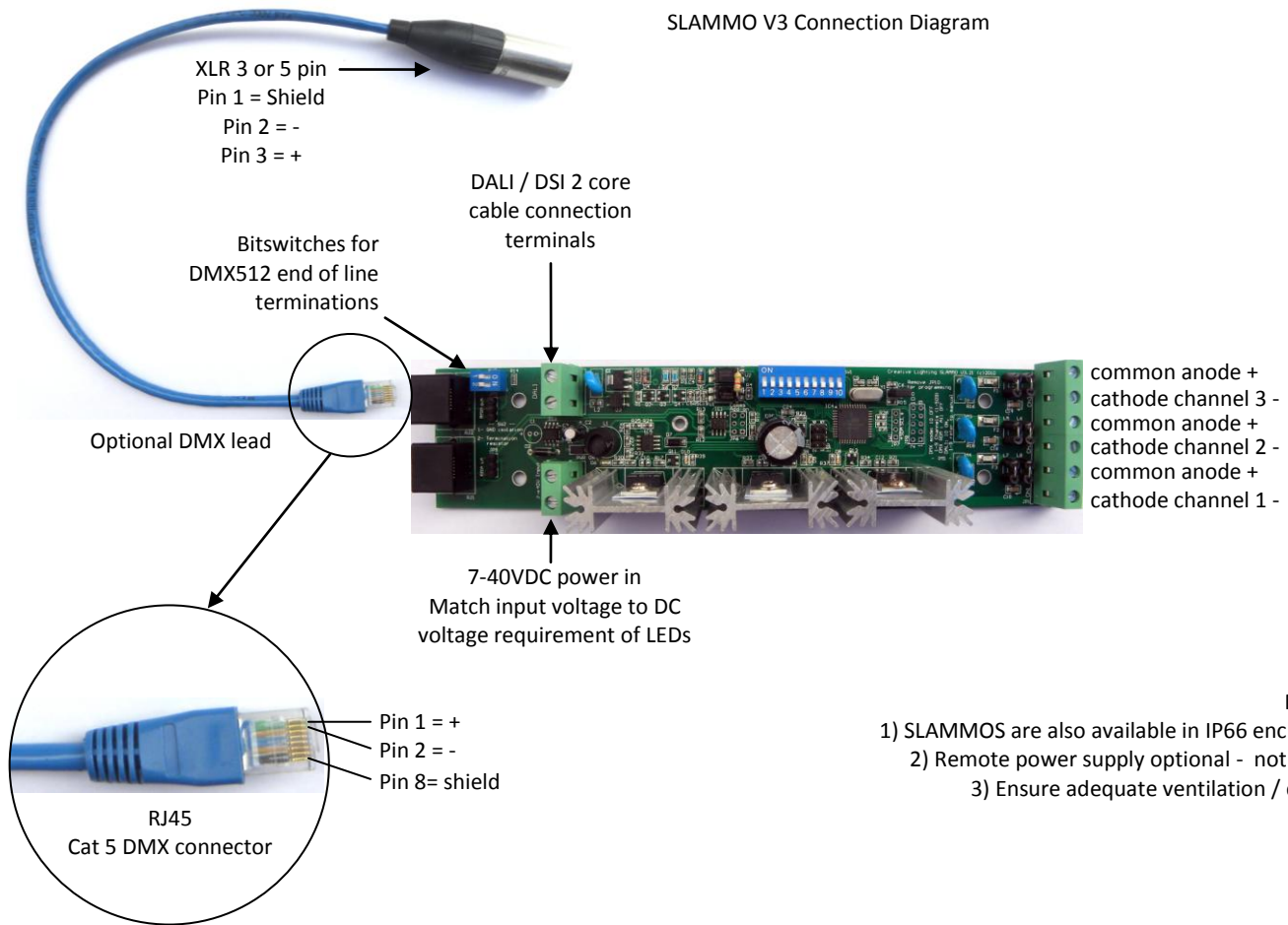

NOTES:

- 1) SLAMMOS are also available in IP66 enclosures
- 2) Remote power supply optional - not shown
- 3) Ensure adequate ventilation / cooling

Other Products

Creative Lighting also manufactures a range of DALI & DMX512 products under our Control Freak trademark:

- DIDIO** DALI & DMX512 controllers, power supplies, scene controllers, sequencers, Serial Communications Interfaces, and translators
- ADDICT** portable tools for installation, configuration, testing, debugging and back-ups
- LIDA** DALI relay and contactor drivers, 1 and 2 channel DALI, for mains rated coils and HID with feedback
- LIDA-F** DALI fan controllers
- SHOWPRO** 10-zone controllers for automated displays and lighting
- TOUCH-TELL** interactive sensors

REGISTRATION – SLAMMO v3

Please complete this form and fax to (+617) 32828700 to register for manufacturer's 24-month warranty.

Name of project _____

Location of project _____

Brief description of project

Purchaser Name _____

Purchaser Company _____

Contact Details – Email _____

Contact Details – Telephone _____

Date of Purchase _____ Quantity purchased _____

Purchased from _____

Warranty

Congratulations on acquiring this genuine Control Freak® product (“the goods”) which is guaranteed to the purchaser for a period of 24 months from the date of original purchase from Creative Lighting and its authorised agents and resellers.

Under normal use and for applications for which this product was designed, this Control Freak® product and all component electronics are warranted to be free of defects in material and workmanship.

In the unlikely event that the goods prove to be defective, Creative Lighting will decide either to repair or to replace the defective components. Before that can happen, the goods must first be returned to Creative Lighting at the purchaser’s cost.

Australia only: If we determine that the goods are defective, we will not only repair or replace the defective components at no cost to the purchaser; we will also pay the cost to return them to the purchaser by our standard freight method, with any cost to reinstall the goods borne by the purchaser.

This Guarantee specifically excludes faults which arise as a result of alteration, tampering, misuse, abuse, accident, vandalism, negligence, improper installation, or the use of other manufacturer’s products in combination with the goods except where such use of other manufacturers goods is authorised by us. All other warranties inclusive of any warranties of merchantability or fitness for any particular purpose whether expressed or implied are hereby expressly negated to the fullest extent permissible by law. Under no circumstances will Creative Lighting be liable for reinstallation or freight except in the case of freight within Australia. In no event shall the manufacturer be liable for consequential damages.

This Guarantee constitutes the sole and exclusive remedy to the purchaser for proven defects.